

ART. 8246 – GIOTTO / 8247 – GIOTTO +

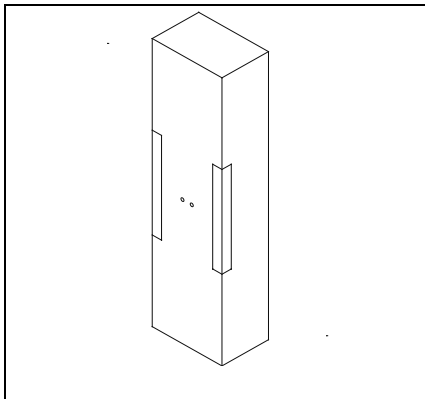

SCHEMA DI MONTAGGIO

SCHEMA DE MONTAGE



- POSIZIONARE IL BASAMENTO IN CEMENTO SU UN FIANCO
- PLACE THE CEMENT BASE ON A SIDE
- POSITIONNER LA BASE DE BETON SUR UNE COTE
- POSICIONAR LA BASE DE CEMENTO SOBRE UN LADO

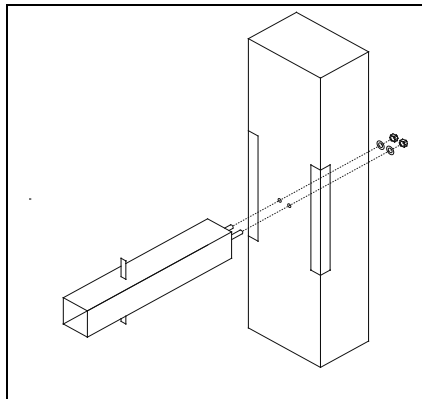

- FISSARE IL PIANTONE IN METALLO SUL BASAMENTO IN CEMENTO CON LE 2 PIASTRINE E I 2 BULLONI
- FIX THE METAL STRUCTURE ON THE CEMENT BASE USING 2 PLATES AND 2 BOLTS
- FIXER LE METAL SUR LA BASE DE BETON A TRAVERS LES 2 PLAQUES ET BOULONS
- FIJAR EL METAL SOBRE LA BASE DE CEMENTO CON 2 PERNOS Y PLACAS

INSTALLATION INSTRUCTION

ESQUEMA DE MONTAJE

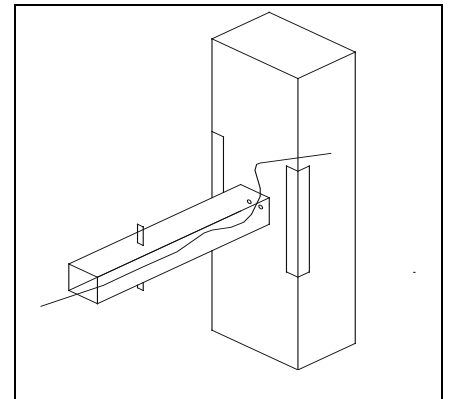

- IN CASO DI ALIMENTAZIONE ELETTRICA DAL PAVIMENTO, INSERIRE IL CAVO ATTRAVERSO IL PIANTONE IN METALLO
- IN CASE OF ELECTRICAL CONNECTION ON THE FLOOR, INSERT THE CABLE INSIDE THE METAL STRUCTURE
- EN CAS D'ALIMENTATION ELECTRIQUE PAR LE SOL, FAIRE PASSER LE CABLE A TRAVERS LE METAL
- EN CASO DE ALIMENTACION DESDE EL SUELO, PASAR EL CABLE A TRAVES EL METAL

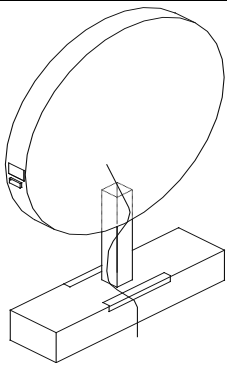

- POSIZIONARE LA SPECCHIERA PRENDENDOLA DAI FORI PER LE PRESE
- PLACE THE MIRROR ON THE SUPPORT HOLDING IT BY THE 2 SOCKETS HOLES
- POSITIONNER LE MIROIR A TRAVERS LES TROUS DES PRISES
- POSICIONAR EL ESPEJO A TRAVES LOS AGUJEROS DE LOS ENCHUFES

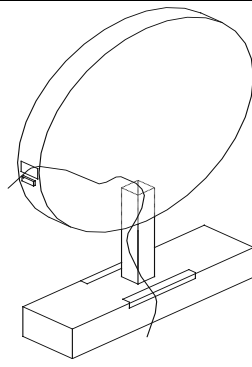

- FARE USCIRE IL CAVO ELETTRICO DAI FORI E COLLEGARE LE PRESE
- EXTRACT THE ELECTRIC CABLE FROM THE SOCKETS HOLES AND CONNECT THE TAPS
- SORTIR LE CABLE PER LES TROUS ET FAIRE LE BRANCHEMENT DES PRISES
- SALIR EL CABLE DESDE LOS AGUJEROS Y CONECTAR LOS ENCHUFES

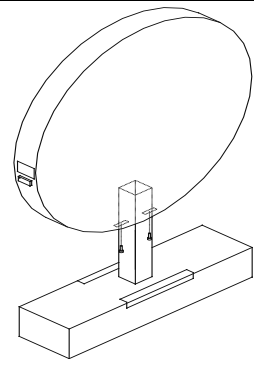

- FISSARE LA SPECCHIERA ALLE SQUADRETTE POSTE SUL PIANTONE
- FIX THE MIRROR TO THE SUPPORT PLACED ON THE METAL STRUCTURE
- FIXER LE MIROIR AUX SUPPORTS PRESENTS SUR LE METAL
- FIJAR EL ESPEJO A LOS SOPORTES SOBRE EL METAL

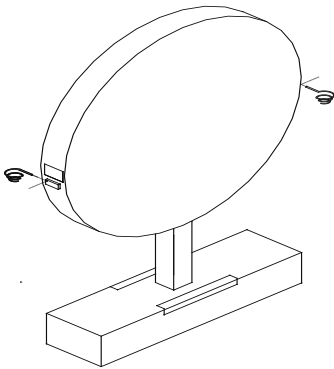

- INCASTRARE IL PORTAPHON NEL FORO ANTERIORE E STRINGERE IL PORTAPHON DAL FORO SUL LATO
- EMBED THE DRYERHOLDER IN THE FRONTAL HOLE AND TIGHTEN THE DRYERHOLDER THROUGH THE LATERAL HOLE
- ENCASTRER LE PORTESECHOIR DANS LE TROU FRONTAL ET SERRER LE PORTESECHOIR A TRAVERS LE TROU LATERAL
- ENCAJAR EL PORTASECADOR EN EL AGUJERO FRONTAL Y SERRAR EL PORTASECADOR A TRAVES EL AGUJERO LATERAL

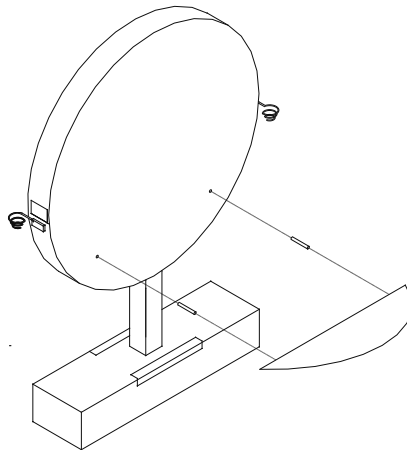

- **PER ART. 8247 GIOTTO +:** AVVITARE I PERNI PORTAPIANO NELLE BOCCOLE E INSERIRE IL PIANO
- **FOR ART. 8247 GIOTTO +:** SCREW THE HINGES TOP HOLDERS IN THE BUSHINGS AND INSERT THE TOP
- **POUR ART. 8247 GIOTTO +:** VISSER LES CHEVILLES PORTE TABLETTE DANS LEURS SIEGES ET INSERER LA TABLETTE
- **POR ART. 8247 GIOTTO +:** ATORNILLAR LOS PERNOS PORTA-ENCIMERA Y PONER LA ENCIMERA

